

Record Rx Doctor VI

User's Guide

Contents

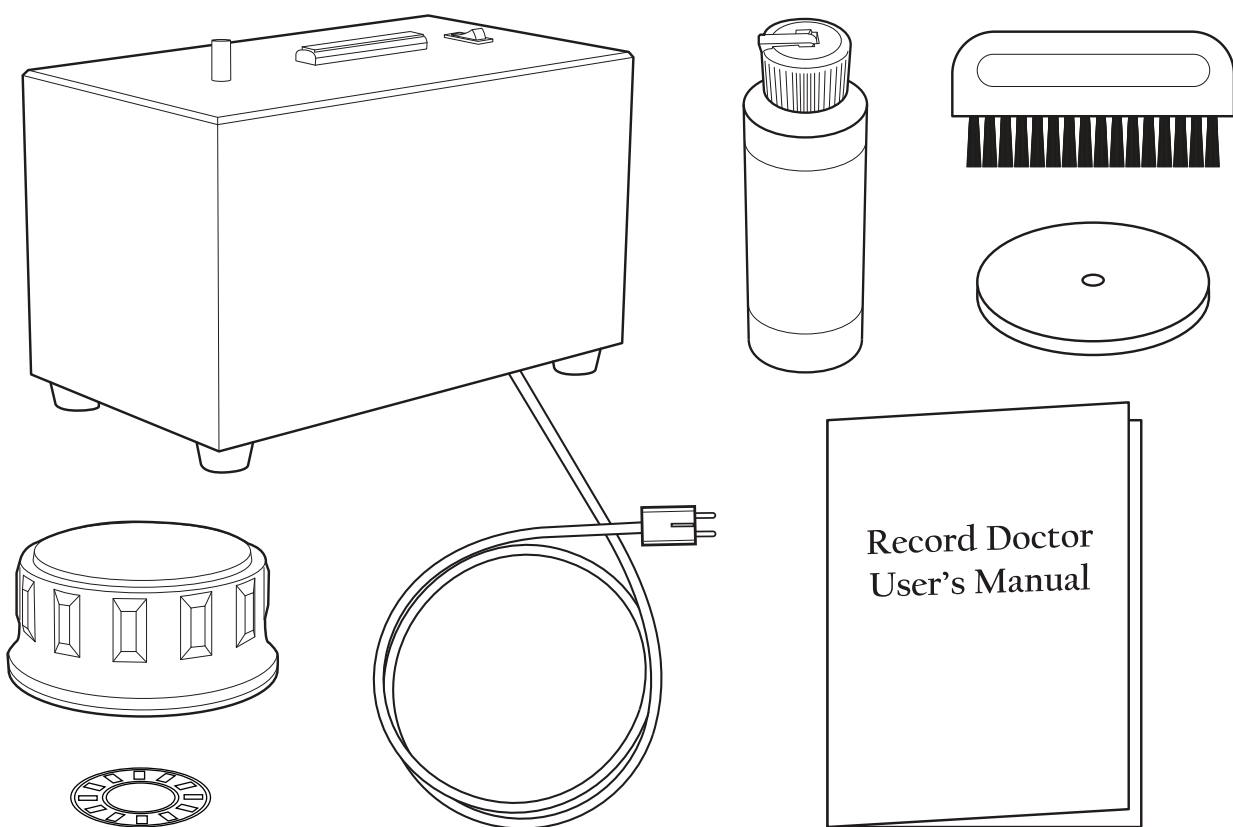

After 20–25 records. Remove drain plug. Drain into sink.

Nach 20-25 Schallplatten. Ablassstopfen ziehen. Flüssigkeit ablassen.

Après 20-25 Disques. Retirez le Bouchon de Vidange. Videz dans l'Évier.

Despues de 20-25 discos. Remover el tapon de drenado. Drenar en lavamanos o cubeta

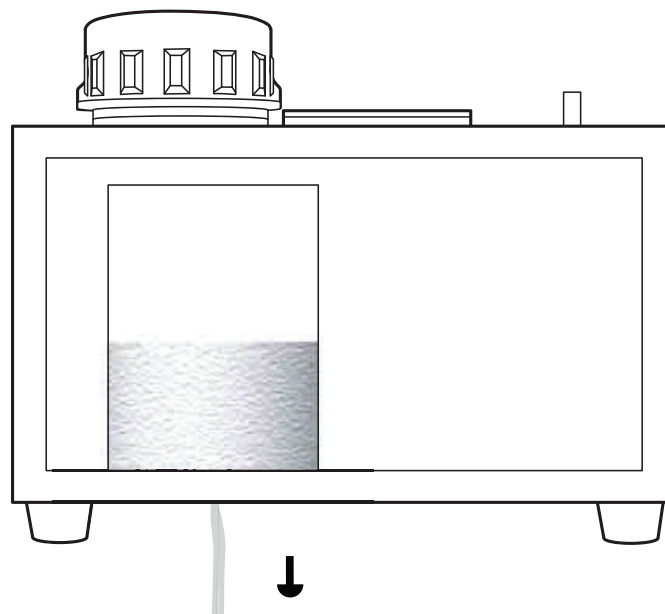
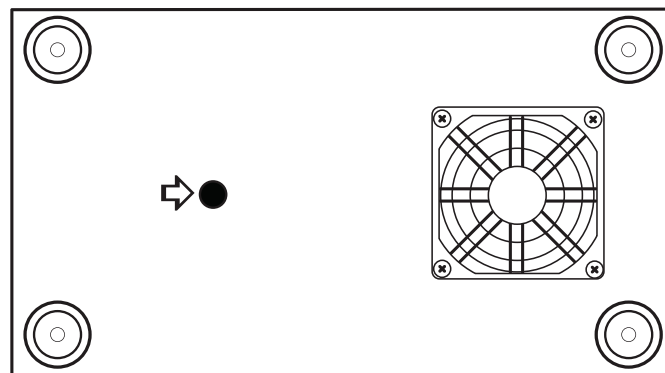
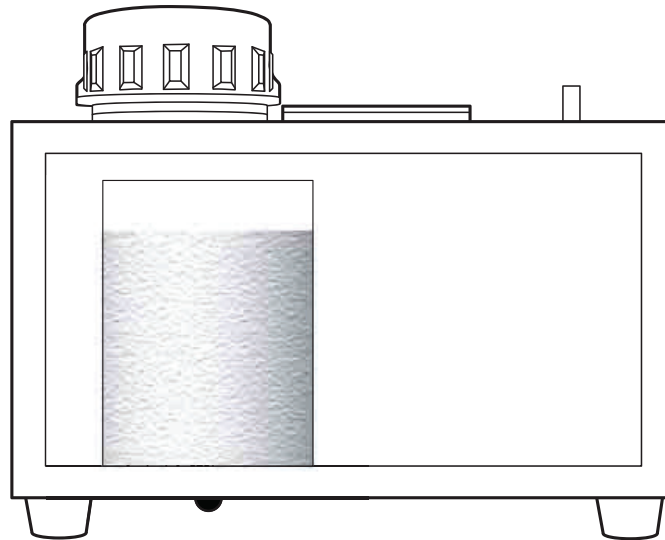

1

EN: Assemble.

DE: Aufbau

FR: Assemblez

ES: Ensamblar

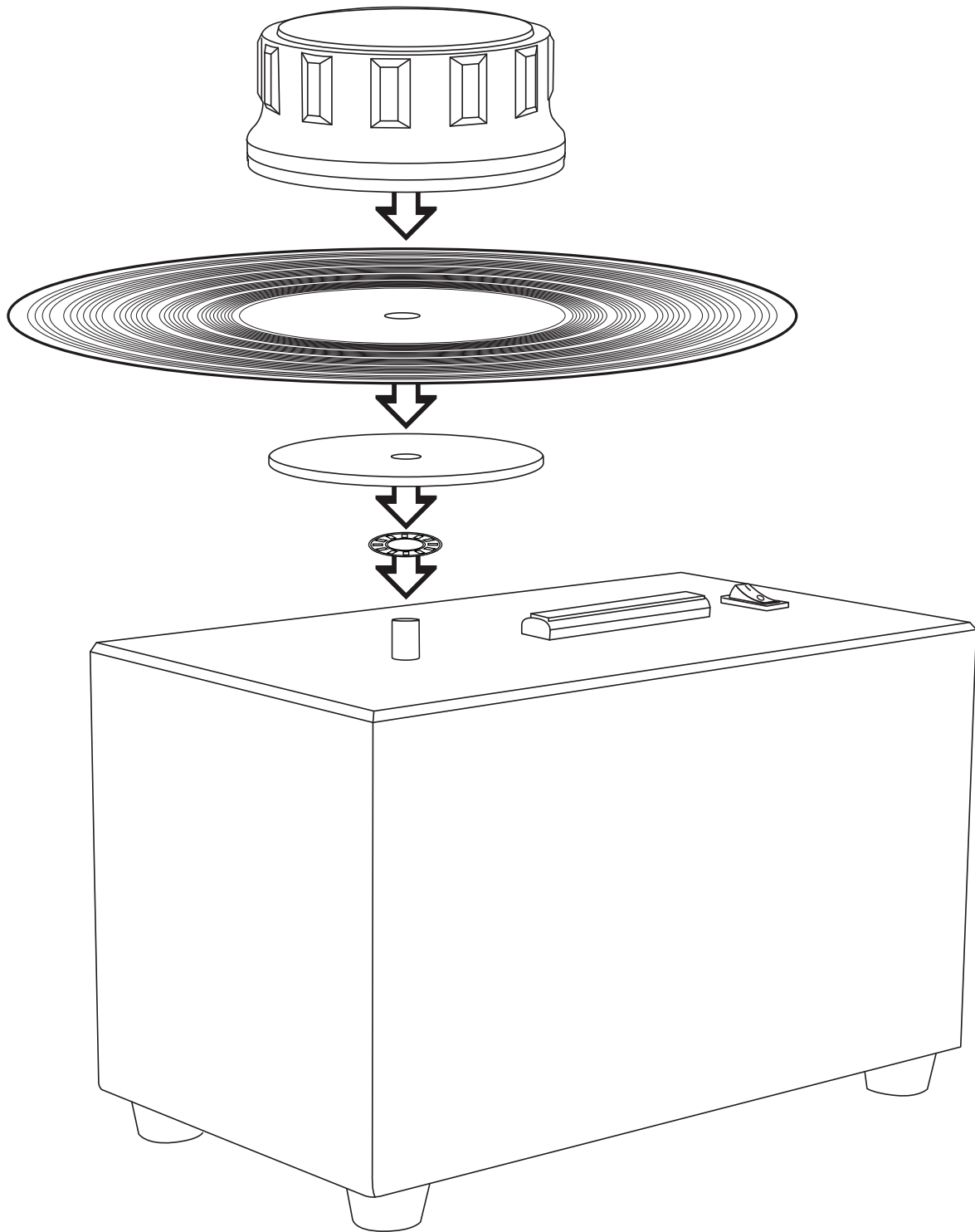

2

Apply fluid.

Reinigungsflüssigkeit auftragen

Appliquez le Fluide

Aplicar fluido

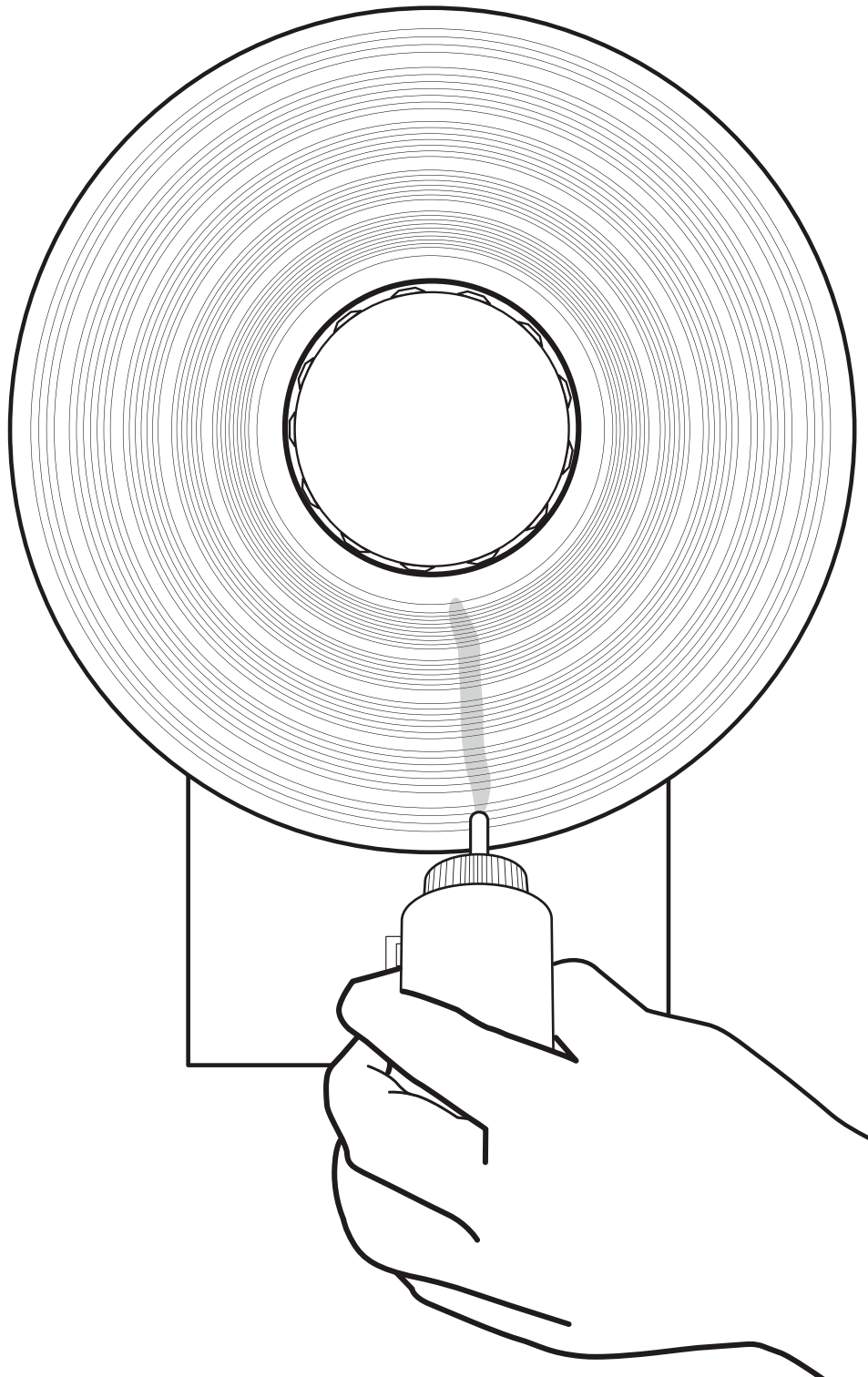

3

Rotate and spread fluid.

Drehen und Flüssigkeit auf der Schallplatte verteilen

Faire Tourner et Épandre le Fluide

Rotar y extender fluido

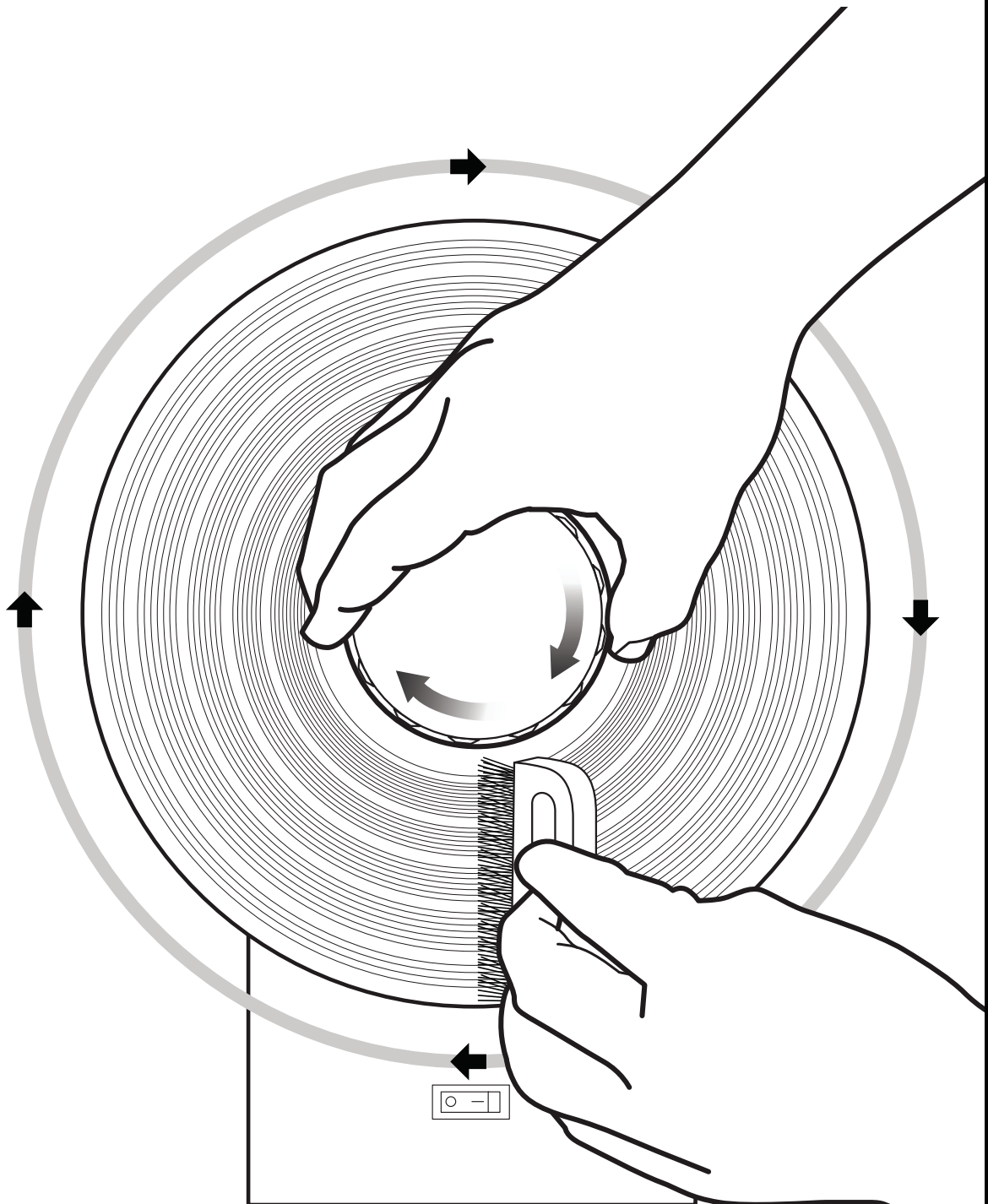

4

Remove turner.

Drehgriff abnehmen

Enlevez le Bouton Tourneur

Retirar rotor

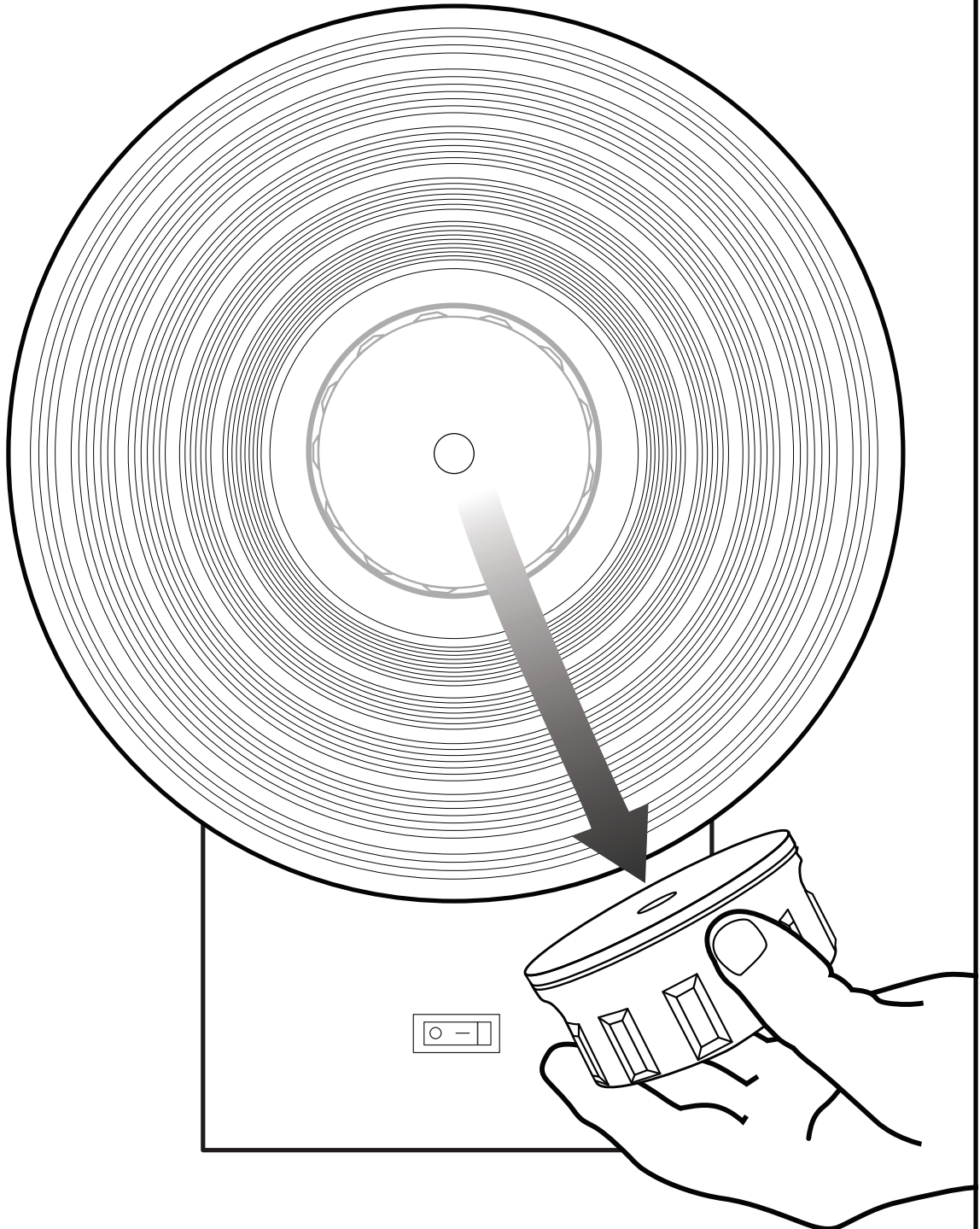

5

Flip record.

Schallplatte umdrehen

Retournez le Disque

Voltear disco

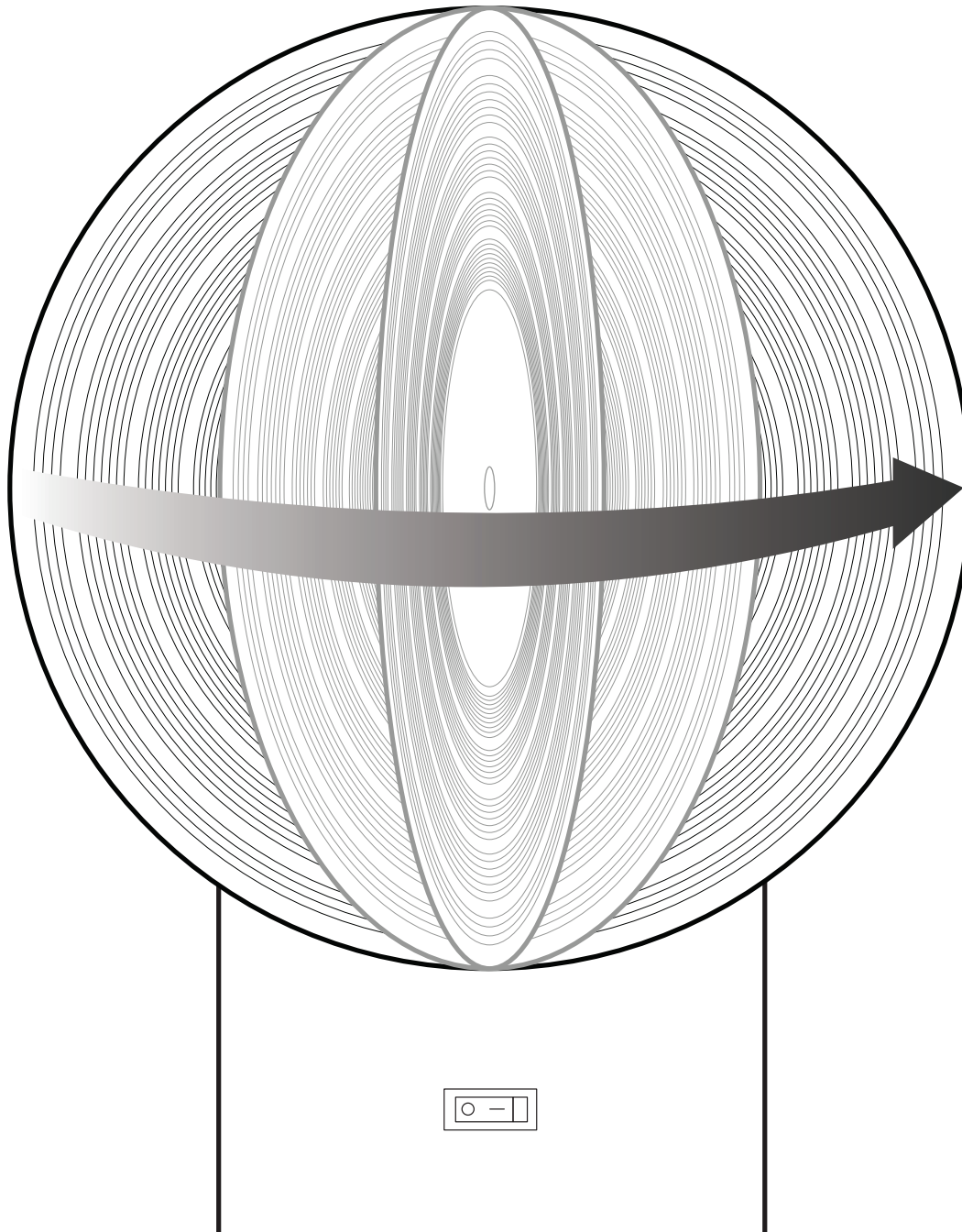

6

Reattach turner.

Drehgriff wieder auflegen

Ré-attachez le Bouton Tourneur

Ensamblar rotor nuevamente

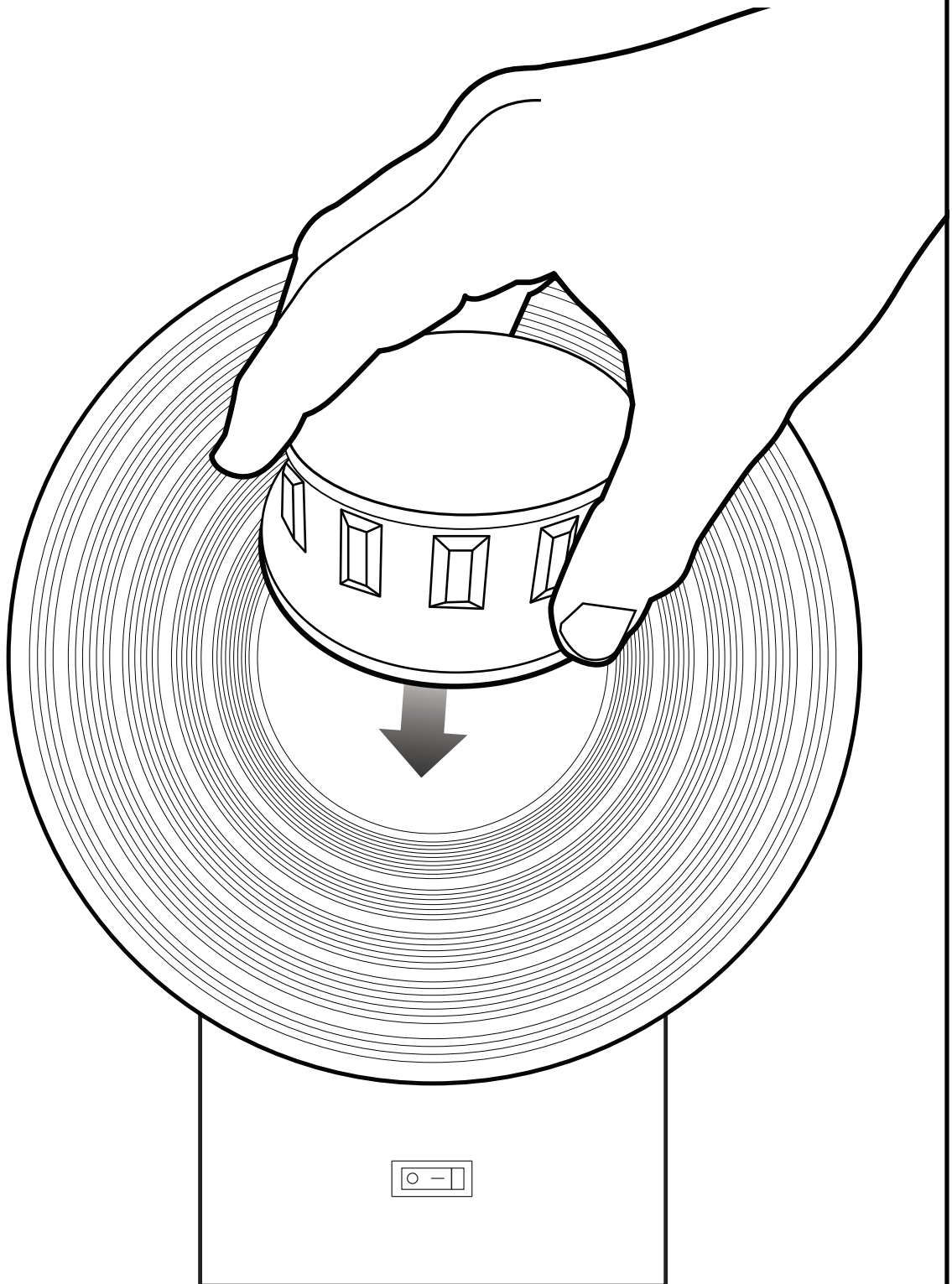

7

Turn machine on.

Gerät einschalten

Allumez la Machine

Encender maquina

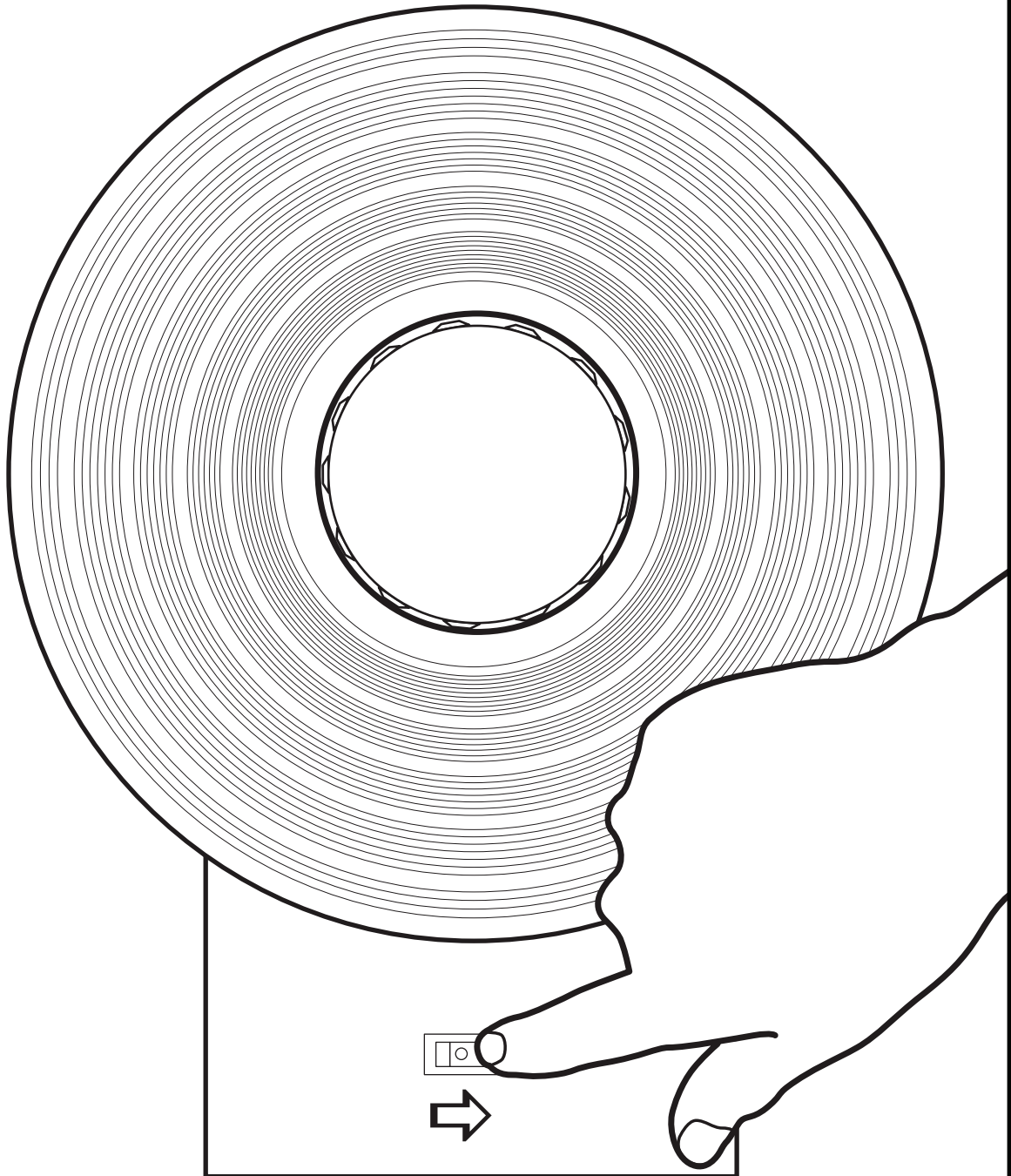

8

Rotate 2–3 times.

2-3 Umdrehungen

Tournez 2-3 fois

Hacer girar el vinilo 2 a 3 vueltas

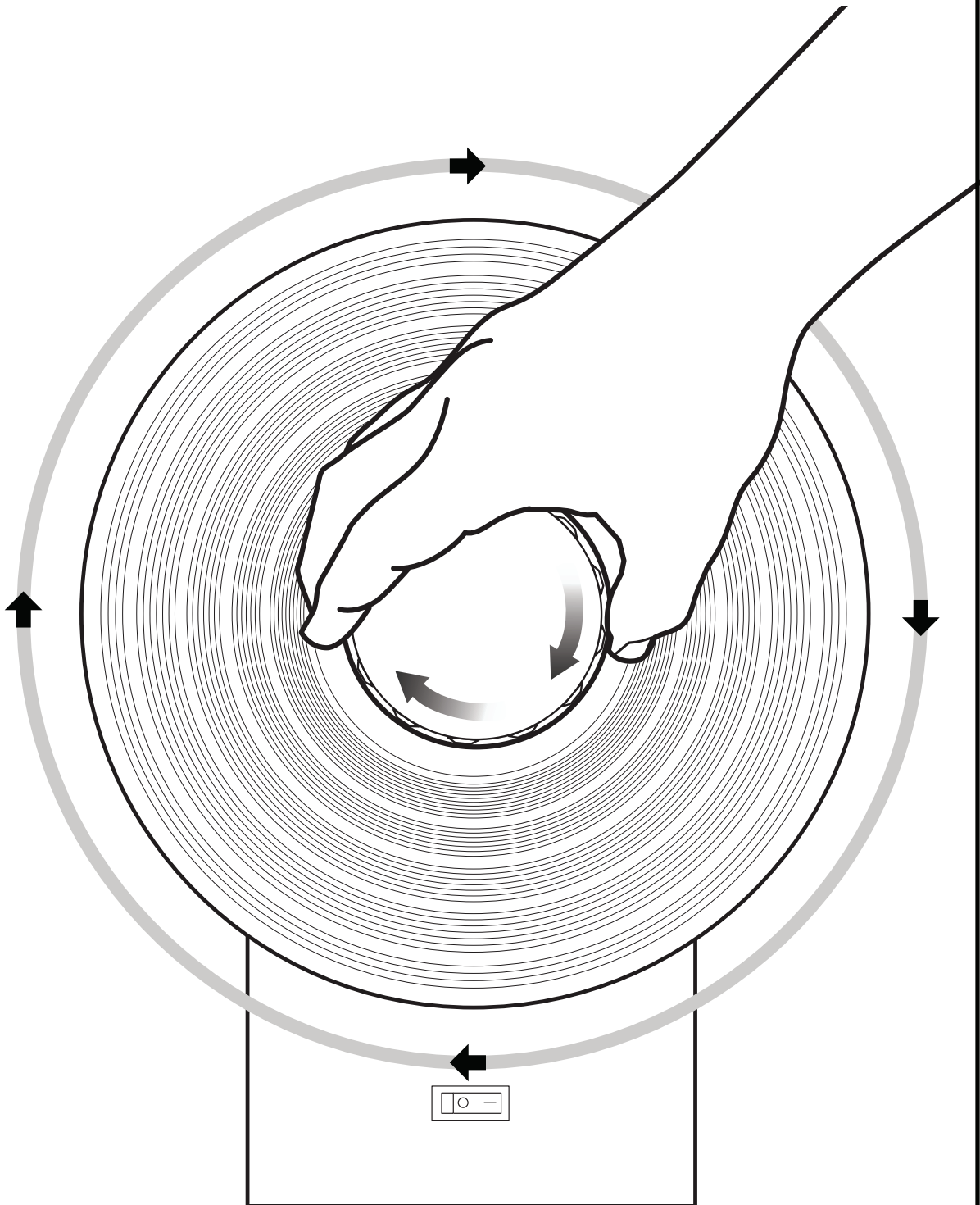

9

Turn off. (Optional: repeat from step 2.)

Gerät ausschalten. (Optional: Wiederholen Sie den Vorgang ab Schritt 2)

Éteignez la Machine. (Optionnel: répétez la deuxième étape)

Apagar maquina. (Opcional: Repetir desde el paso 2.)

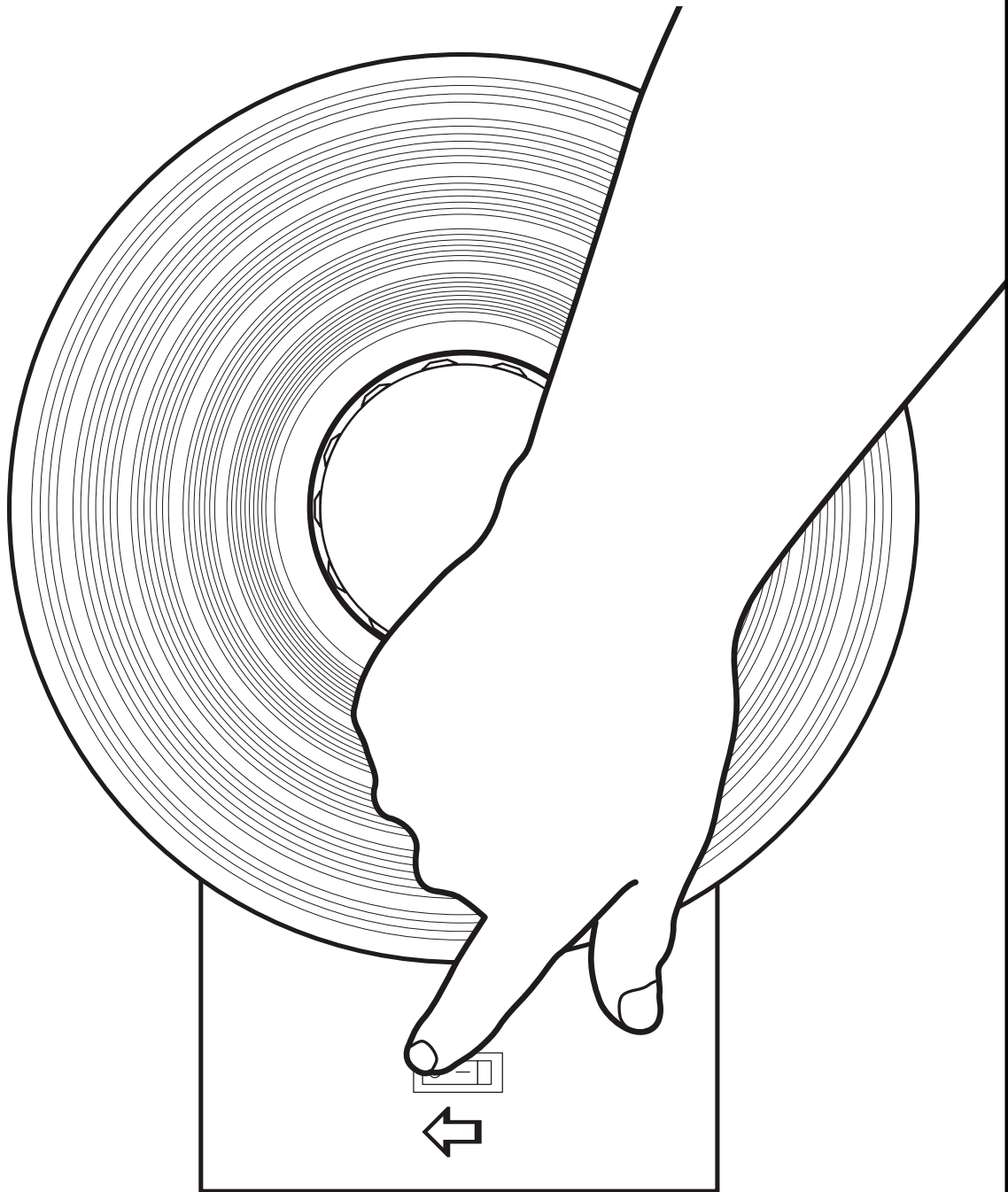

10

Play that clean vinyl.

Gereinigte Schallplatte abspielen

Faites Jouer le Disque Propre

Tocar ese disco limpio en tu tornamesa

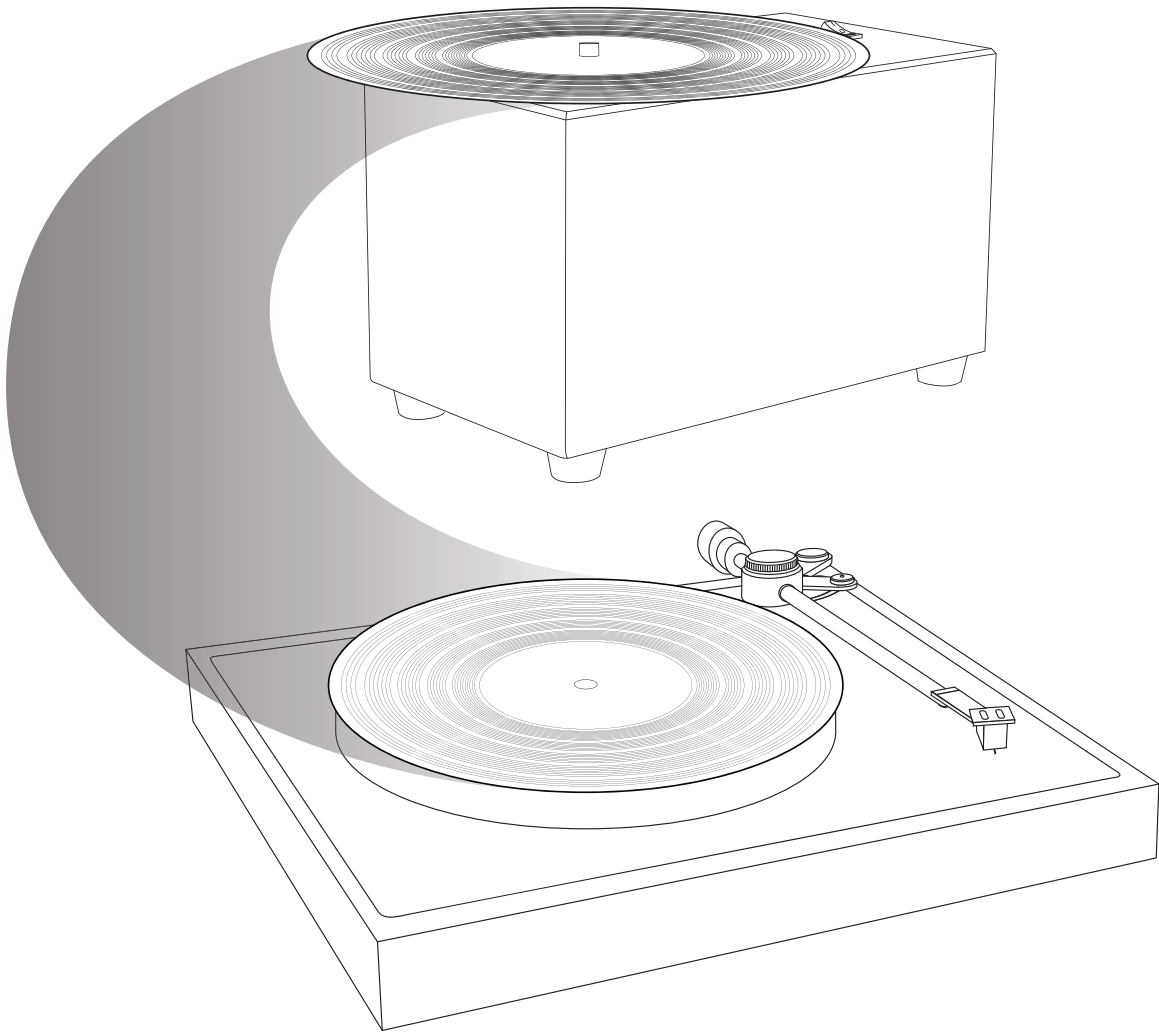



Thank you for purchasing
the Record Doctor VI
record cleaning machine.

Record Doctor VI

Safety & Use Guidelines

The Record Doctor VI machine was designed and produced under strict quality controls. It complies with all established international safety standards. The following instructions should be fully read, understood, and observed in order to prevent any hazard, personal injury, or damage:



Do not attempt to open the machine or attempt to service inside! Severe risk of damage and electric shock! There are no parts in the machine that require maintenance by the user.



Cleaning

Unplug the machine from the wall before cleaning the machine's cabinet. Use a soft, lint-free cloth. Do not use abrasives, solvents, thinners, chemicals, polishes, or other cleaning products that may permanently damage the finish.

Guidelines for Operation

- Always use in a well-ventilated area.
- Do not block the bottom vent while operating.
- Do not run the vacuum motor continuously while cleaning. Turn on and off as needed.
- If the machine becomes warm to the touch, stop cleaning and allow the machine to cool for at least an hour.
- The maximum recommended cleaning capacity is one hundred (100) LPs per day.
- Do not reuse spent fluid, which may damage your records.
- Never vacuum a dry record! This may damage the LPs surface.
- Regularly clean the Record Doctor cleaning strips with a soft toothbrush.
- Always replace the cleaning strips at the first signs of wear (SKU: RDSSK)

Warranty

The Record Doctor VI is guaranteed against manufacturing defects for a period of one (1) year after the purchase date. User abuse, misuse, the use of unauthorized cleaning solutions, or shipping damage voids this warranty. For warranty service, visit www.pangeaaudio.com or call (866) 984-0677.